

- 1
- 2
- 3
- 4
- 5
- 6
- 7
- 8
- 9
- 10
- 11
- 12
- 13
- 14
- 15
- 16
- 17
- 18

## MATERIAL

Cast aluminium, fine sandblasted matte surface, turned and mirror-polished rim.

## STANDARD EXECUTIONS

H7 reamed hole.

- **GN 321-A**: without handle.
- **GN 321-R**: with revolving handle in polyamide based (PA) technopolymer, black colour, matte finish.

## SPECIAL EXECUTIONS ON REQUEST

- Handwheels with safety GN 000.5 (see page 160).
- GN 323 handwheels with black epoxy resin coating, matte finish.
- Handwheels with keyway in compliance with DIN 6885/1 tolerance P9 (see page A-15).



Conversion Table	
1 mm = 0.039 inch	
d1	
mm	inch
80	3.15
100	3.94
125	4.92
140	5.51
160	6.30
200	7.87
250	9.84

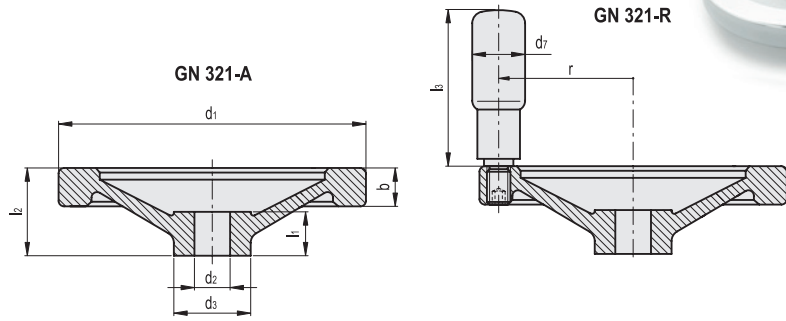

## GN 321-A

Code	Description	d1	d2 H7	d3	b	l1	l2	⚖
GN.25501	GN 321-80-B10-A	80	10	26	13	16	26	134
GN.25511	GN 321-80-B12-A	80	12	26	13	16	26	127
GN.25521	GN 321-100-B10-A	100	10	28	14	17	30	215
GN.25531	GN 321-100-B12-A	100	12	28	14	17	30	213
GN.25541	GN 321-125-B12-A	125	12	31	15	18	33	318
GN.25551	GN 321-125-B14-A	125	14	31	15	18	33	298
GN.25561	GN 321-140-B14-A	140	14	36	16.5	19	36	431
GN.25571	GN 321-140-B16-A	140	16	36	16.5	19	36	427
GN.25581	GN 321-160-B14-A	160	14	36	18	20	39	570
GN.25591	GN 321-160-B16-A	160	16	36	18	20	39	560
GN.25601	GN 321-200-B18-A	200	18	45	20.5	24	45	885
GN.25611	GN 321-200-B20-A	200	20	45	20.5	24	45	884
GN.25621	GN 321-250-B22-A	250	22	48	23	28	51	1522
GN.25631	GN 321-250-B26-A	250	26	48	23	28	51	1479

## GN 321-R

Code	Description	d1	d2 H7	d3	b	l1	l2	l3	r	d7	⚖
GN.25505	GN 321-80-B10-R	80	10	26	13	16	26	44	33.5	16	161
GN.25515	GN 321-80-B12-R	80	12	26	13	16	26	44	33.5	16	154
GN.25525	GN 321-100-B10-R	100	10	28	14	17	30	58.5	42.5	18	255
GN.25535	GN 321-100-B12-R	100	12	28	14	17	30	58.5	42.5	18	253
GN.25545	GN 321-125-B12-R	125	12	31	15	18	33	61.5	54	22	394
GN.25555	GN 321-125-B14-R	125	14	31	15	18	33	61.5	54	22	374
GN.25565	GN 321-140-B14-R	140	14	36	16.5	19	36	76.5	61	24	507
GN.25575	GN 321-140-B16-R	140	16	36	16.5	19	36	76.5	61	24	503
GN.25585	GN 321-160-B14-R	160	14	36	18	20	39	76.5	71	24	675
GN.25595	GN 321-160-B16-R	160	16	36	18	20	39	76.5	71	24	665
GN.25605	GN 321-200-B18-R	200	18	45	20.5	24	45	86.5	89	25	990
GN.25615	GN 321-200-B20-R	200	20	45	20.5	24	45	86.5	89	25	988
GN.25625	GN 321-250-B22-R	250	22	48	23	28	51	86.5	113	25	1626
GN.25635	GN 321-250-B26-R	250	26	48	23	28	51	86.5	113	25	1583